

Testing, Repairing & Installing Home Telephone Wiring



Disclaimer

This information is intended to assist customers of telephone service to understand the telephone wiring in their home. This information, if used properly, can be helpful in fixing or installing telephone wiring in your home. Use of this guide is at your own risk. Improperly installed wiring could impair your phone service. Although the voltage on active telephone wiring is typically very small, it can be hazardous to some individuals and materials. In addition, telephone wiring can conduct dangerous electrical shocks if it comes into contact with power wires. Caution should be used at all times. *The Public Service Commission or your telephone service provider have no responsibility for any personal injury or property damage which may result from your installation or attempted installation of inside wiring as discussed in this guide. By proceeding with installation, you assume all risk of personal injury or property damage, including but not limited to: loss of service, damage to property, or injury. If you do not fully understand the concepts laid out in this guide and are not completely comfortable performing the work, do not attempt the installation or repair. Instead contact a professional such as your telephone service provider.*

Components of your Telephone System

When planning where to put your telephone jacks, the best place to start is the demarcation point between your wiring and the wiring of the telephone company:

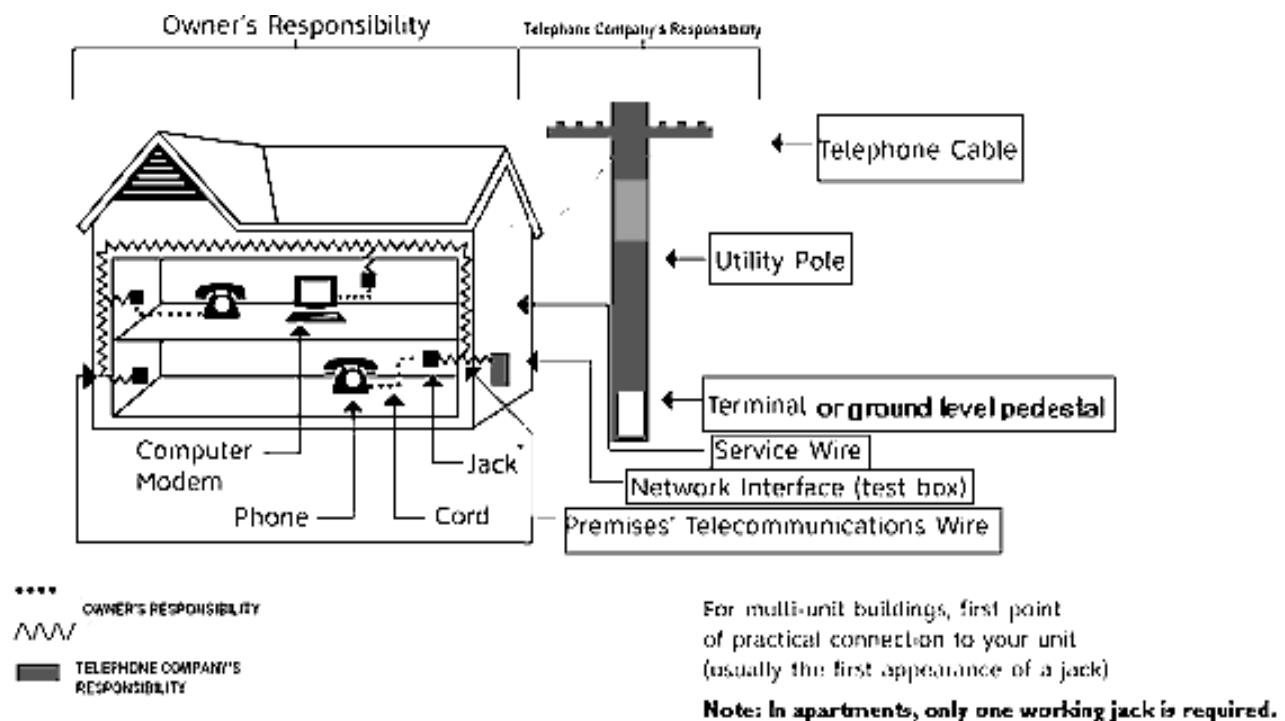

Locating the “Demarcation Point”

Your telecommunications company maintains the wiring up to a demarcation point. The demarcation point is typically at the “Network Interface Device” (“NID”). This device is usually located on the outside of your home. If you have an older home or have a home alarm system, the demarcation point may be found at a “Network Interface Jack” which is inside your home, at the point where the telephone wiring enters your home.

Note: If you subscribe to telephone service from your cable television provider or from an alternative provider (like a VoIP provider), the information contained here may not be helpful to you and could harm your equipment. Attempting to work on these other systems may result in a loss of service.

You may also have different components if you have a “fiber to the home” application. Further, if you are attempting to install a digital subscriber line (DSL) for broadband Internet service, this information may not be sufficient.

If you do not fully understand which system you have or you are not confident in your ability to work on the components of your system (regardless of whether it is depicted in this information or not), you should contact your service provider to install new components or troubleshoot existing ones.

If you cannot locate either a NID or a Network Interface Jack, it may be helpful to contact the telephone company to determine where your demarcation point is located.

If you live in a multi-unit or multi-tenant building, you may want to contact the property manager or condo association to determine where these devices are located in your building. Your local service provider may also be able to help you determine where the demarcation point is. You will also need to contact your landlord to determine whether they are responsible for repair of the telephone inside wire on their premises.

The Network Interface Device

When working in or near that NID, be sure to be careful. Aside from being the device where the telephone service wire connects to the inside wire, the NID also provides electrical protection through the electrical grounding system on the customer's premises, so any work you do on the NID could have an effect on how these electrical systems are grounded.

NOTE: The NID and/or Network Interface Device is maintained and installed by your local service providers. In many cases, there may not be a charge for a new installation, however, if you wish to have your NID moved for convenience or aesthetics or if you have damaged the NID, a charge will typically apply. Contact your local service provider for more information.

The device itself will have 3-5 posts that interconnect the telecommunications company's wire to your inside wire. If the NID is located outside your house, it will have a plastic cover. You will need to remove this cover to access the wiring, but since this cover is an important protector of the telephone equipment, it must be properly reinstalled after your work is completed. The telephone company side of the NID is locked and you should not attempt to open it.

A typical network interface device will include a “test jack” that looks like a typical modular telephone outlet, as is show here:

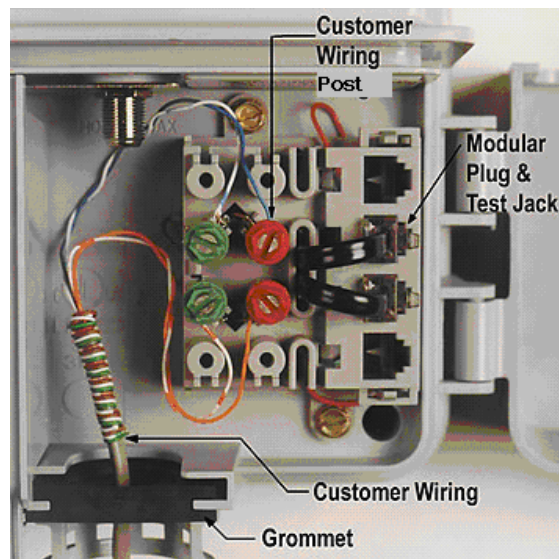

By unplugging the short wire and plugging a working phone directly into this jack, you can determine whether a problem is in the home (wiring, jacks or telephone equipment) or in the telephone company’s lines. It is recommended that you use a wired telephone (i.e., not a cordless phone) for this test since a cordless phone may actually be the cause of static or other noise on the line. If the phone does not operate using the test jack, you should call your telephone company because the trouble is in the network leading up to your network interface device. If the phone operates when you have plugged it into the test jack, the fault is in the inside wiring, jacks or telephone equipment and is the customer’s responsibility.

If you do hear a dial tone when testing from the test jack, you have three choices:

- Call your local telephone company to receive a quote to repair your inside wire or to place a repair order (note that some companies do offer repair insurance programs that allow you to pay a monthly fee to have your inside wire covered by a repair plan. Contact your local provider if this service is of interest to you).
- Call a contractor to repair the service. Contractors are listed in your telephone directory.
- Repair the trouble yourself (this guide is directed towards those who choose this option)

Modular Outlets

In older homes, where the wiring to the demarcation point may prove to be more difficult, planning may begin at the most convenient modular outlet. Modular outlets are the typical phone jacks into which you currently plug your telephone (or “Customer Premise Equipment”). There are a variety of modular outlets available on the market today to suit individual needs. Some of the more common modular outlets look like:



Starting from a modular jack, and with some modifications, you will be able to extend or move service from an existing jack to a more convenient place in your home.

Safety First

Telephone installation work is generally safe provided you follow these guidelines:

- Do not work with outlets and wires that you are not sure are telephone facilities. If you are unsure which facilities are or are not telephone facilities, you should consider consultation with an experienced professional.
- Do not connect household electrical power to telephone lines.
- Do not work on any telephone wires (or any wires) during a thunderstorm.
- Work with insulated tools.
- Touch only one wire at a time.

Note: When working with telephone wires and connections, there is always the possibility of an electrical shock. It is generally recommended that premises wiring be disconnected from incoming telephone lines. Do this at the NID. You may also choose to lift the handset of one telephone connected to the line as a means of avoiding electrical power surges which occur when your telephone rings.

Compliance with Local Building and Safety Codes

When planning and installing your telephone wiring and outlets, you must observe and comply with any applicable state and local codes. The state code can be found at the Wisconsin Administrative Code, Commerce Chapter 16, which is available at:

<http://www.commerce.state.wi.us/SB/SB-DivCodesListing.html>

Before doing any significant wiring work, you may want to consult with your municipal government to determine if permits are necessary for the work you plan to do.

Before You Start

Before starting any telephone installation work, familiarize yourself with the products, procedures and safety precautions outlined in this brochure. Be sure to review the safety precautions included with any equipment you have purchased as well. As you work on your telephone wiring (or any wiring) the motto “safety first” should be your guide.

The telecommunications industry has become increasingly diverse with the types and number of services that are available, as well as the types and number of service providers. The information contained in this brochure is intended to be a guide for the “typical” situation involving telephone wiring. However, depending on the type of service you are using (i.e., cable modem, digital subscriber line (DSL) (or any high-speed internet service), VoIP etc...) you may need to refer to other materials.

This guide will be particularly helpful if you wish to change phones, add an extension, or install your own wiring system. To do so, you must use FCC approved jacks and telephone industry standard wiring, which are widely available at electronics and home improvement stores.

List of suggested Tools and Materials

- Screwdriver
- Hammer
- Needle nose pliers
- Wire stripper
- Drill
- Fish tape or chain
- Diagonal wire cutters
- Tape measure
- Drill and assorted bits
- Marking pencil
- Nails to mount outlet boxes
- Standard electrical outlet boxes
- Jacks as required
- Network interface wire junction
- Staples and staple gun

NOTE: if used properly, staples can be a convenient way to secure wiring. However, you need to use care to ensure that you do not pierce the wiring when securing it with a staple.

Planning the Wiring Job

As is true with most home improvement projects, a good plan is the foundation for success. Before purchasing any telephone wire and accessories, carefully plan the installation job to determine which components you will need. You will need to consider where you want to locate modular jacks for greatest convenience and ease of use. You will also want to consider your telecommunications needs for both now and the future since this could affect your choice of wire, which comes in various categories (CAT 1, 2, 3, 4 and 5 (additional information about the various types of wire is found in a chart at the end of this document).

Telephone wire: CAT 5 cable is the most commonly used today and is recommended. You are encouraged to use CAT 3 cable at a minimum to allow for the best service quality. Additionally, you will need to decide which type of jack is best for the particular location. One thing to consider is the use of outlets with protective covers in areas where there may be excessive exposure to dust or moisture.

Helpful hints for Installation

- Place as much wire as possible in "nonliving" areas such as basements or attics.
- "Fish" wire through walls to basement areas where possible, especially on interior walls. Exposed wires are more susceptible to damage from pets, children furniture and vacuum cleaners.
- When drilling "blind" holes through walls or floor spaces, be sure you know where the drill will exit.

- Be sure there are no electrical, plumbing, or heating facilities to damage.
- Avoid making sharp corners with wire. Corners should be rounded and fasteners placed within a few inches of the bend.
- When possible, wires "spanning joists" should be kept 2" to 3" from protective parts of the building such as sills, beams or walls.
- Telephone wires should never be spliced. When it's necessary to extend an existing wire, a wire junction block should be used in making connections.
- A tool which is designed to remove insulation should be utilized when stripping wires rather than a sharp knife which could nick a conductor and result in a service problem.

It is recommended only one wire conductor be placed between any two washers on a terminal post. If more than one conductor is necessary, additional washers should be added. All wire should be looped in the same direction as tightening of the nut.

Wire Routing Strategies

There are two standard routing strategies:

1. Continuous Loop: In this method a single wire runs from the demarcation point to a jack, then another wire runs to the next jack and so on, forming one continuous loop. But, like Christmas tree lights, if the wire gets cut somewhere, all the jacks beyond the cut will be disabled. This method may also make it more difficult to add a 2nd or 3rd line somewhere in the house.

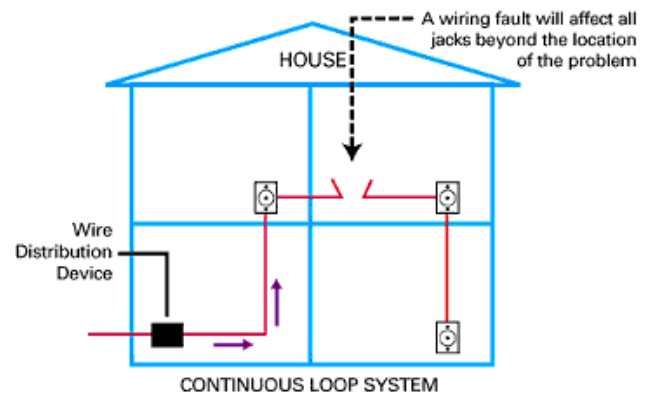

2. Star Pattern or "Home Run:" As the name implies each jack is wired separately and directly to a central point where they can be connected to the telecommunications company's wiring. This system may take more time and use more wire, but it more easily accommodates future growth and trouble-shooting problems.

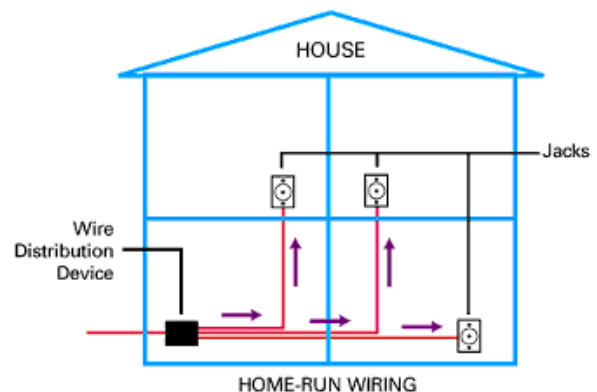

You may even find a combination of these strategies where there is a continuous loop on a floor of a house, but each floor feeds independently to the demarcation point. In older condo and apartment buildings you are likely to find a continuous loop, but newer buildings are incorporating the “home run” method.

Telephone Wiring

Telephone wire normally used for inside installation contains four individually colored conductors. The wire is solid copper in either 22 or 24 gauge. See Tables A and B for wire color codes and spacing from other wire conductors.

Telephone Wire

The dial tone arrives at your home on two wires which are typically twisted together to form a “twisted pair.” While twisted pairs can be bunched together to form large cables, by the time the connection reaches your home, it has typically been reduced to an aerial drop wire (which contain 1 to 6 pair), or a buried drop wire (which contain 1 to 6 pair).

In order to tell the various wires and pairs apart, there is an industry standard color coding system. Be aware, however, depending on who installed the wire, there may be variances. However, if a professional installed the wiring, they should have followed this color coding system.

Your single-line phone system will work properly when the wire color pattern is consistent with each wire secured to its proper terminal on a jack or spliced to the same color (as in a junction block where a system branches). The table on page 6 identifies wire connections on jack terminals and pair identifications for splicing.

Installation in New Construction

The best time to place wiring for telephone service is before the wallboard or wall covering has been placed. The method of installing telephone wire is similar to that of installing wire for electrical outlets. That is, you start from one point, run wiring to the first location, from that location to the next location.

The telephone company will install the **Network Interface**. The starting point for your wiring is at the jack/outlet box you provide adjacent to the **Network Interface** (it should be within six inches). By comparison, the **Network Interface** is like your power meter and the jack/outlet you install is like your power panel. It is from the jack outlet that you provide that the wiring must start, and run to all other modular outlets.

Table B: Wire Connection and Coding Chart

Pair No.	Jack Screw Designation	2-Pair Wire Color	3-Pair Wire Color	4-Pair Wire Color
1	R or R1	Red	Red	Blue with White Stripe
	G or T1	Green	Green	White with Blue Stripe
2	Y or GN	Yellow	Orange with White Stripe	Orange with White Stripe
	B or AUX	Black	White with Orange Stripe	White with Orange Stripe
3			Green with White Stripe	Green with White Stripe
			White with Green Stripe	White with Green Stripe
4				Brown with White Stripe
				White with Brown Stripe

As an example, in order that the telephone company and you have a common point to wire to, the location of the wiring starting point will be the location of the power panel. If this location has a hollow wall (wall studs), it is suggested that you place two outlet boxes at this location, one for the left side of a stud and one for the right side of the same stud. The telephone company can then install the **Network Interface** into one of the outlet boxes and you can install a jack for your inside wiring in the other (this arrangement should be on an outside wall if possible). This will provide a method to connect your inside wiring to the **Network Interface** with a short eight inch standard FCC plug-to-plug cord.

For wiring in a new construction, it is recommended to use at least 4-pair wire for the concealed portions of the wiring (the portions that will be behind the drywall). Using this type of wire will make additional connections easier in the future.

- Concealed wiring should be installed prior to the walls being covered by insulation and drywall
- Plan your wire routing to avoid future problems including overheating (i.e. place the wire away from elements that may get hot like recessed lighting) or moisture (i.e., place the wiring away from plumbing fixtures).
- Start a new wiring run for each jack.
- Run the wire through holes drilled in the studs and floor joists.
- Leave extra wire at each end of the installation for when you make the connection.

Installing Telephone Outlet Boxes:

In new constructions, many homeowners install outlet boxes in the wall that will be flush with the wall, like an electrical outlet. Depending on the use of the phone, the outlet boxes will need to be at different heights:

- For desk phones, the standard height is 14 inches from the bottom of the outlet box to the floor.
- For wall-mounted telephones, the recommended height is 58 inches from the bottom of the box to the floor.

Where a wall telephone is to be placed over a countertop, the recommended height is 10 inches from the bottom of the box to the counter; however, there must be enough room below and above the outlet box to allow the telephone to be installed.

Before mounting the outlet boxes, determine the amount of protrusion required beyond the stud to assure that the outlet box will be flush with the finished wall surface. The standard wallboard coverings could alter this figure. If you do not know how thick the wall covering will be, check with your contractor. Standard protrusion is 3/8". However, this will vary with wall surface thickness.

Adding Wire to Existing Service:

When adding wiring to existing telephone service, you must run the wire from a known working telephone outlet, wire junction, or the NID. The wiring will then be connected to a working outlet or feed for the new telephone location or locations.

This will typically mean that the new wire will be visible (as opposed to having the wire run through the floorboards and studs as is available in a new construction). 2-pair wire is normally used in this situation. Standard baseboard jacks are easiest for this type of installation.

Helpful Hints:

- Start at the point where you intend to install a telephone jack.
- Leave at least 12 inches of extra wire at the planned location of the jack.
- Leave at least 3 feet at the point of connection to your current telephone wiring.
- Fasten the wire to the baseboard and moldings using a staple gun or a wire clip every 12 inches. Pull the wire straight (but do not stretch it) before installing a staple or clip
- Be careful not to drive the staples or clips through the wire
- Do not run the wire on the floor or under carpets. Normal activity can damage the wiring and cause it to break.
- Do not run the wiring through or near heating ducts unless the wire is rated for this type of installation. Heat can cause the wires to become brittle and break.
- Do not wrap the wire around nails or hooks.

Connecting the wires

1. Using a wire stripping tool, remove about 4 inches of the outside plastic sheath (usually beige or grey) that bundles the wires together. Be careful not to nick insulation or cut the wires beneath the sheath.

- Using a wire stripping tool, remove about 1 inch of the plastic insulation from each of the colored wires to expose the copper as shown here:

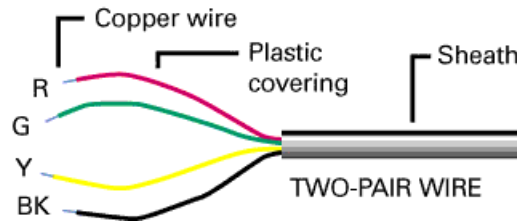

Nowadays, it is more common to see 4-twisted pair wiring like this:



It is called “Cat 5” cable and is the national standard for all new telephone wiring projects.

- Fasten the jack casing securely to the wall or baseboard using the appropriate metal or wood screws. Pull the wire through the opening in the jack casing and connect it as depicted here:

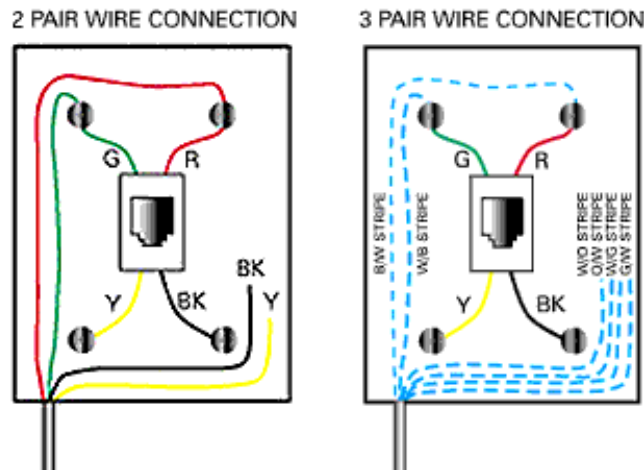

4-Pair Wire Connection: A 4-pair cable is wired to a standard jack as shown in the 3-pair wire diagram above but also leaving the brown wires aside.

- Match each colored wire to the appropriate terminal on the jacks as shown in the diagrams. In the old standard color scheme the first pair has one green wire ("tip") and one red wire ("ring"). The second pair has one black wire ("tip") and one yellow wire ("ring"). For a single phone line, only the green and red pair is normally used. The black and yellow pair is normally spare and available to install a second phone line. **For multi-line installations see wiring options at the end of this booklet.**

5. Ensure that no copper wire is touching any exposed metal inside the jack or electrical box.
6. Ensure that all connections are secure.
7. Place the jack cover over the casing and either snap or screw it into place.

At the Demarcation Point:

8. Strip the wire sheath and colored wires the same way you did for the jacks.
9. Connect the wires that come from each jack location to the entry wiring at the demarcation point. Be sure to match the colors correctly.

Repairing inside wire yourself/ Trouble Shooting

Ensure that your inside wire is connected properly at the demarcation point. You can determine a lot about the trouble by listening to sounds on your telephone line:

Static: Wires could be wet or pierced. Wires could be loose at a connecting point. Carefully check all wires and connections.

Buzzing or Humming: A wire may have come into contact with metal, other than the connection terminals. Is any exposed copper wire touching the box or other metal around the jack? Check that colors have been matched correctly. Also, if you are using a cordless phone, you should try plugging in a wired telephone to ensure that the problem is not with your equipment. Given the nature of a cordless phone, it is possible that buzzing or humming is coming from the phone itself and not your wiring.

Dead Air: Wires may be crossed. Is there a contact between any exposed copper from wires of different colors (red crossed with green if 2-pair wire is being used; or blue crossed with white if 3-pair wire is being used)?

Cross Talk: Be sure you are not using a cordless phone, since cross talk is likely from the wireless nature of the phone. If you have multiple phone lines in the home or are in a multi-unit dwelling, cross talk could be the result of damages or faulty wiring.

Check that all connections have been made properly. Are all the colored wires connected to the right terminals? Is the exposed copper wiring making a solid contact with the right terminals?

Check the wire. Is it broken or split? Is it pierced by a staple, nail, screw or other object? If it is, replace the entire section of wire from end to end.

Check that the pins or connecting terminals inside the jacks are not touching each other and that a jack itself is not damaged.

How many phones do you have? It may be possible that your phones are drawing too much energy and compromising the system as a whole. Unplug a few phones and see if the problems persist.

Modem problems? If you are having problems connecting to the Internet, the problem may be with the modem. Try disconnecting the computer and use a standard telephone and see if there are problems on the line. If the line does not show a problem, the issue is likely with your computer equipment. This is also true if you are using a Digital Subscriber Line (DSL) (or other high speed internet service) which may involve separate filters that could cause problems on the line, even though the line is working properly.

To isolate a trouble in your inside wire:

- Locate your wire distribution device (connector block) at your demarcation point;
- Disconnect one pair of wires from the distribution device;
- Check to see if your service has been restored at other jack locations in your home;
- Continue disconnecting wire pairs, one pair at a time, to determine which wire is the cause of the trouble;

Once you have isolated the problem circuit, it is suggested that you replace the entire section of wire that is defective or the jack if it is causing the problem.

If you are unable to repair or isolate an inside wire trouble yourself, repair service is available from your local telephone company or an independent contractor. Be aware that charges may apply for these services if you do not subscribe to a monthly insurance plan through your local service provider.

Information for Multiple Phone Line Installations

Two lines can be connected to single jacks or two lines can be wired to double jacks according to the following diagrams and using the terminals and wires (or their color equivalents shown in this table):

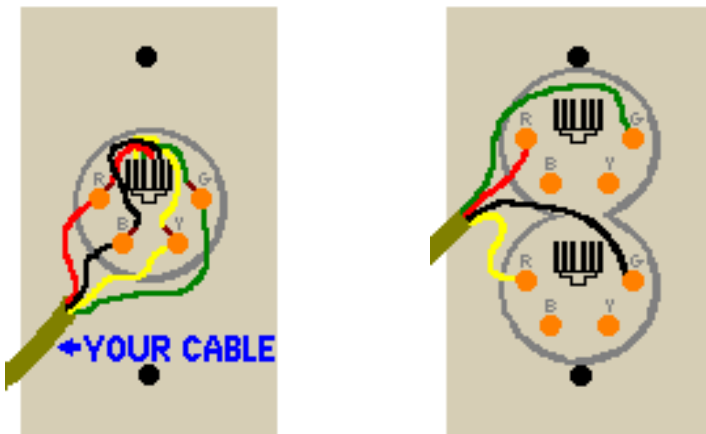

Four lines can be set up on double jacks using the pattern below:

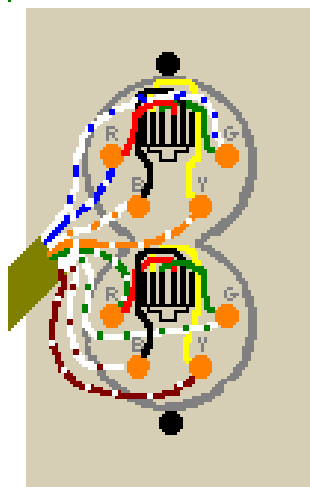

The following chart shows wiring patterns and jack/plug names for installing up to three phone lines using single jacks and plugs.

Wiring patterns and jack/plug names

Pin	RJ25	RJ14	RJ11	Pair	T/R	Color	Old
1	X			3	T	white/green	orange
2	X	X		2	T	white/orange	black
3	X	X	X	1	R	blue or blue/white	red
4	X	X	X	1	T	white/blue	green
5	X	X		2	R	orange or orange/white	yellow
6	X			3	R	green or green/white	blue

For key systems and other multi-line equipment, 4-pair cable can be connected to RJ-61 plugs and jacks that allow up to four phone lines.

They have a wider 8-pin plug and an 8-terminal jack as shown below:

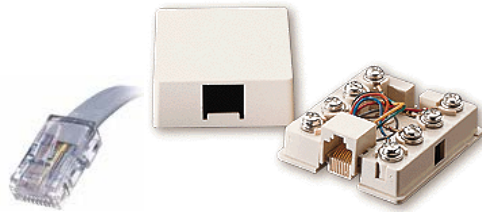

In such installations a phone or fax machine with a standard plug can still be connected to a properly wired RJ-61 jack to access the first or second line, but an RJ-61 plug would be needed to use the third or fourth line.

Wiring patterns can vary for specific 4-line (RJ-61) and data (RJ-45) installations so you will want to reference a guide for your specific equipment or specific data application.

Wire Category Table:

Cat XX wire reference is a specified category of performance for inside wire and cable systems.

Category	Cable Type	Application & Speed Supported
1	Unshielded Twisted Pair	Analog Voice
2	Unshielded Twisted Pair	Digital Voice, 1 Mbps Data
3	Unshielded Twisted Pair/Shielded Twisted Pair	16 Mbps Data
4	Unshielded Twisted Pair/Shielded Twisted Pair	20 Mbps Data
5	Unshielded Twisted Pair/Shielded Twisted Pair	100 Mbps Data
5e	Unshielded Twisted Pair/Shielded Twisted Pair	Up to 1000 Mbps Data
6	Unshielded Twisted Pair/Shielded Twisted Pair	1000 Mbps Data
7*	Unshielded Twisted Pair/Shielded Twisted Pair/Fiber	1000 Mbps Data
* Proposed Standards		

The Public Service Commission of Wisconsin is an independent state agency that oversees more than 1,100 Wisconsin public utilities that provide natural gas, electricity, heat, steam, water and telecommunication services.



Public Service Commission of Wisconsin

P.O. Box 7854

Madison, WI 53707-7854

Telephone: 608-266-5481

Toll free: 888-816-3831

Consumer affairs: 608-266-2001 / 800-225-7729

TTY: 608-267-1479 / 800-251-8345

Fax: 608-266-3957

Website: <http://psc.wi.gov>